

Model 522

*Manual/Remote Controlled (GPIB Programmable)
DC Voltage/Current Calibrator*



**KH KROHN-HITE
CORPORATION**

Operating Manual

This page intentionally left blank.

**PROGRAMMABLE
DC VOLTAGE CALIBRATOR
CURRENT**

Model 522

Serial No. _____

522 OPERATORS MANUAL



Copyright © 1999

Electronic Development Company
Division of KROHN-HITE
15 Jonathan Drive Unit 4
Brockton, Massachusetts 02301
E-mail: Info@krohn-hite.com
www.krohn-hite.com

All rights reserved. No part of this publication may be reproduced, stored in a retrieval system or transmitted in any form by any means, electronic, mechanical photocopying, recording, or otherwise, without the prior written permission of Electronic Development Company

Printed in U.S.A.
Version 3.27
Revised January 2003

Information furnished in this manual is believed to be accurate and reliable. However, no responsibility is assumed by Electronic Development Company for its use; nor for any infringements of patents or other rights of third parties which may result from its use.

522 TABLE OF CONTENTS

<u>SECTION</u>	<u>TITLE</u>
i	List of Drawings
ii	Limited Warranty
iii	Factory Service Request and Authorization
iv	Packing Suggestions
I	DESCRIPTION AND SPECIFICATIONS
1.1.0	General Description
1.2.0	Features and Applications
1.2.1	Features
1.2.2	Applications
1.3.0	Output Specifications
1.4.0	General Specifications
1.5.0	Mechanical Specifications
1.6.0	General Information
II	INSTALLATION
2.1.0	Mounting
2.2.0	Mating Connectors
2.3.0	IEEE 488 Cables
2.4.0	AC Power Input Considerations
2.5.0	Thermal Considerations
III	OPERATION OF THE INSTRUMENT
3.1.0	Front Panel Controls
3.2.0	Front Panel Indicators
3.3.0	Output Connections
3.4.0	Remote Programming with the IEEE 488 Bus
3.5.0	Remote Programming with the RS-232 Option
3.6.0	Voltage Compliance Limit Control
3.7.0	Operating Voltage Conversion
IV	THEORY OF OPERATION
4.1.0	Introduction
4.2.0	Control Board
4.3.0	Microprocessor Circuits
4.4.0	Digital Board IEEE 488 Logic
4.5.0	Digital to Analog Converter
4.6.0	Output Amplifier
4.7.0	Output Switching
4.8.0	Range Logic



TABLE OF CONTENTS (Continued)

V CERTIFICATION AND TESTING

- 5.1.0 Recommended Equipment
- 5.2.0 Calibration Procedure

VI OPTIONS - (If Installed)

- 6.1.0 1 Volt Option RA-7
- 6.2.0 Calibration. of the RA-7 option.

VII PARTS LIST

- 7.0.0 Replacement Parts for Model 522

NOTE: Errata and addendum (if any) will appear in the back of this manual.

522 MANUAL LIST OF DRAWINGS

DESCRIPTION	DRAWING #
MPU Flow Chart	A-4634 Rev. A
IEEE-488 Logic Schematic	A-4610 Rev. D
1V Range Board Schematic - Option RA-7	A-4636 Rev. F
1V Range Board Layout - Option RA-7	A-4817 Rev. F
System Block Diagram	B-4633 Rev. A
Power Supply Schematic	B-4615 Rev. B
522 Control Board Schematic (Displays)	B-4819 Rev. A
522 Control Board Schematic (Switches)	B-4820 Rev. A
MPU Board Schematic	B-4763 Rev. A
DAC Schematic	C-4614 Rev. C
Range Logic Schematic	B-4611 Rev. B
Output Amplifier Schematic	B-4613 Rev. B
Output Switching Schematic	B-4612 Rev. C
522 Control Board Layout	B-4822 Rev. A
MPU Board Layout	B-4765 Rev. A
Motherboard Layout	B-4630 Rev. I
Motherboard Layout	B-4631 Rev. I
Reference Drawing	930727A
Front or Rear Terminal Connector	CB-4718

LIMITED WARRANTY

The ELECTRONIC DEVELOPMENT COMPANY (E.D.C.) warrants to the original purchaser each instrument manufactured by them to be free from defects in material and workmanship. This warranty is limited to servicing, repairing and/or replacing any instrument or part thereof returned to the E.D.C. factory for that purpose in accordance with the instructions set forth below; and furthermore to repair or replace all materials, except tubes, fuses, transistors and other semiconductor devices which shall within ONE YEAR of shipment to the original purchaser be returned to the E.D.C. factory and upon examination be deemed defective.

E.D.C. instruments may not be returned to the factory under the terms of this warranty without the prior authorization of the E.D.C. Service Department. All instruments returned to E.D.C. for service hereunder should be carefully packed and shipped. All transportation charges shall be paid by the purchaser.

EDC reserves the right to discontinue instruments without notice and to make changes to any instrument at any time without incurring any obligation to so modify instruments previously sold.

This warranty is expressly in lieu of all other obligations or liabilities on the part of EDC. No other person or persons is authorized to assume in the behalf of EDC any liability in the connection with the sale of its instruments.

CAUTION: *The instrument you have purchased is a precision instrument manufactured under exacting standards. Any attempts to repair, modify or otherwise tamper with the instrument by anyone other than an EDC employee or authorized representative may result in this warranty becoming void.*

FACTORY SERVICE REQUEST AND AUTHORIZATION

WARRANTY SERVICE

Instruments may be returned only on prior authorization. Please obtain a RETURN AUTHORIZATION NUMBER either directly from the factory or from an authorized E.D.C. Representative. (See General Information below.)

CHARGEABLE REPAIRS

If requested, an estimate of charges will be submitted prior to repairs. We suggest that you request a RETURN AUTHORIZATION NUMBER to facilitate handling.

GENERAL INFORMATION

A) Please provide the following information in order to expedite the repair:

- 1) Indicate MODEL
- 2) Serial Number
- 3 Complete description of the trouble:

Symptoms, measurements taken, equipment used, lash-up procedures, attempted repairs, suspected location of failure and any other pertinent information.

B) Freight Charges must be PREPAID.

C) The RETURN AUTHORIZATION NUMBER should be noted on your documentation.

D) See Packing Suggestions - next page.

PACKING SUGGESTION

Although your E.D.C. instrument is built for laboratory, production environment and some field environment, it is NOT ruggedized. Therefore ...

1. Be sure the carton is **STRONG** enough to carry the weight of the instrument, e.g. use double wall corrugation.
2. Be sure the carton is **LARGE** enough to allow for sufficient packing material, e.g., at least 2 inches all around the instrument. The packing material should be able to be compressed and then return to its approximate original volume.
3. For better handling, the shipment should always be by **AIR FREIGHT** (expect for short distances). You might use either UPS "blue label" or common air freight carrier, second day air.

Please do not bounce it across the country in a truck. It may not hurt it, but it certainly is not going to do a laboratory instrument much good.

4. **QUESTIONS?** Just contact us. We will be pleased to help you.

SECTION I

1.0.0 DESCRIPTION AND SPECIFICATIONS

1.1.0 General Description

- 1.1.1 The EDC Model 522 is a microprocessor controlled enhanced version of the field proven Model 521. An industry standard 6500 series microprocessor has been incorporated to improve the reliability, and versatility of the instrument.
- 1.1.2 The Model 522 Programmable DC Voltage Standard is a highly versatile reference source, designed to meet the needs of computer systems, production line testing, automated calibration, and standards laboratories.
- 1.1.3 The instrument has a specified accuracies, that are traceable through a bank of saturated standard cells to the U. S. National Institute of Standards and Technology.
- 1.1.4 Resolution of each range, in each function, is 1 part per million.
- 1.1.5 The instrument is a highly accurate reference which can be used for calibration of digital voltmeters, analog meters, semiconductor analyzing systems, analog references for computers, analog-to-digital converters, telemetry and data acquisition systems, and wherever a stable source is required.
- 1.1.6 The variable, constant current mode is designed for use in calibration and simulation of strain gages and other transducers.
- 1.1.7 There are no adjustments made during normal operation; the trims are made during calibration and are described in the calibration procedure.
- 1.1.8 The circuitry is completely solid state made of discrete, hybrid and/or integrated circuits packaged on etched glass circuit boards. These are proven circuits, using derated components to insure long life and maximum reliability.
- 1.1.9 The instrument is overload and short-circuit proof, and is fully operational in normal environmental conditions.
- 1.1.10 The Standard Source will drive a short circuit indefinitely without damage to the instrument, and will recover to rated specifications in less than 100 μ s.

1.2.0 Features and Applications

1.2.1 Features:

Accuracies based on one full year calibration cycle and conservatively specified by using the "Limit of Error" (or Worst Case) methods.

E Mode: $\pm(0.002\%$ of setting + 0.0005% of range + $2\ \mu\text{V}$)

I Mode: $\pm(0.005\%$ of setting + $200\ \text{nA}$)

Programming: IEEE-488 (GP-IB) and local/manual control. *(Note): Operator has control of local/remote mode i.e., shutdown not required to re-establish "local" control.)*

3 Voltage ranges (1 ppm resolution or 6 decades)

$\pm 100\ \text{Vdc}$ resolved to $100\ \mu\text{V}$

$\pm 10\ \text{Vdc}$ resolved to $10\ \mu\text{V}$

$\pm 100\ \text{mVdc}$ resolved to $0.1\ \mu\text{V}$

2 Current ranges (1 ppm resolution or 6 decades)

$\pm 100\ \text{mAdc}$ resolved to $0.1\ \mu\text{A}$

$\pm 10\ \text{mAdc}$ resolved to $0.01\ \mu\text{A}$

(Note: $100\ \text{Vdc}$ Compliance with variable control.)

Floating output. Optically isolated between analog output and digital input lines.

True bipolar control with balanced zero.

Magnitude is maintained during polarity changes, and scaled on function changes and range changes in the manual mode. i.e., this eliminates the requirement of re-entering the magnitude.

A "crowbar", or short circuit, of the output may be selected.

Alpha-numeric dot matrix display, for ease of reading and less digital noise on the analog output.

1.2.2 Applications:

Calibration of DVMs, DMM, meters, chart recorders, A/D converters, ATE, monitors, controllers, logging systems, etc.

Simulation of thermocouple and strain gages. (4 to $20\ \text{mA}$ and 10 to $50\ \text{mA}$) and other transducers.

NOTE: Compliance voltage from $1\ \text{V}$ to $100\ \text{Vdc}$. Compliance limits are selectable. Linearity check of amplifiers and function modules.

1.3.0 Output Specifications

1.3.1 Voltage Mode

Range (Full Scale)	100 mVdc ±111.111 0 mVdc	10 Vdc ±11.111 10 Vdc	100 Vdc ±111.111 0 Vdc
Resolution (1 ppm)	100 nV	10 µV	100 µV
Compliance Current	EMF into 1 meg Ohms	100 mA	100 mA
Output Impedance	20 Ohms	10 mOhms	10 mOhms

Accuracy (Basis for accuracy statement):

The Accuracy Statement is based on the "Limit of Error" (or "worst case") method. All other specifications noted hereafter, which effect accuracy, e.g., line, load, temperature, and drift changes are included in the accuracy statement. Thus, all other specifications are listed as *non-Additive.

±(0.002% of setting + 0.0005% of range + 2 µV)

Note: The "+ 2 µV" specified above applies primarily to the 100 mV range where measurements at these low levels should be stated conservatively. It becomes insignificant on the higher ranges.

Note: The accuracy statement above is based on the "Limit of Error" method and is VALID FOR ONE YEAR calibration cycles. The "Limit of Error" accuracy may be increased to tighten tolerances by:

- A) Shortening re-calibration cycle, i.e., more frequently than the suggested 1 year cycle. and/or
- B) Elimination of "worst case" conditions by implementing carefully monitored, standards laboratory procedures.

Stability: (*non-additive)

8 hrs: ±0.00075%;	24 hrs: ±0.001%
90 days: ±0.0015%	1 yr: ±0.002%

Line & Load Regulation: (*non-additive)

±0.0005% No load to full load for a ±10.0% line fluctuation

1.3.2 Current Mode

Range	10 mAdc	100 mA
Full Scale	±11.111 10 mAdc	±111.111 0 mAdc
Resolution (1 ppm)	10 nA	100 nA
*Compliance Voltage	0 - 100 Vdc	0 - 100 Vdc
Output Conductance	0.1 μs	0.1 μs

**Note: Voltage Compliance Limit Control - See para 3.6.0.*

Accuracy: (See definitions under Voltage mode)
±0.005% of setting + 200 nA

Stability:(*non-additive)

8 hrs:	±0.00075%	24 hrs:	±0.001%
90 days:	±0.0015%	1 year:	±0.002%

Line & Load Regulation:

±0.0005% from short circuit to full compliance and/or for a ±10% line fluctuation.

1.4.0 General Specifications

Isolation:

Power Transformer to analog output: 2.5×10^4 M Ohms, 300 pF Control logic to analog output; optically isolated. 10^9 Ohms, 130 pF, 500 Vdc

Temperature Coefficient:

Ambient: ±0.0005% / °C
Operating Limit: ± 0.001% / °C

Switching and Settling Times:

Step Changes: 5 ms
Range Changes: 300 ms

Protection:

Voltage mode: Short-circuit and overload protection.
Current mode: Open-circuit protection.
Front panel enunciator and alpha-numeric display will indicate malfunction condition.

Warm-up Time: 1 hour to rated accuracies

1.4.1 Noise & Ripple: The following specifications are furnished in detail so the user can have complete confidence in the results of their tests.

PEAK-TO-PEAK (Typical Performance)

IMPROVED NOISE SPECIFICATIONS

0.1Hz To:	100Hz	1kHz	10kHz	100kHz
100mV range	10 μ V	15 μ V	35 μ V	45 μ V
10V range	30 μ V	50 μ V	100 μ V	150 μ V
100V range	300 μ V	400 μ V	600 μ V	600 μ V

1.5.0 Mechanical Specifications

Power Requirements: 70 W; 115 V or 230 Vac \pm 10%; 50/60 Hz
See paragraph 3.7.0 for power line voltage changing instructions.

Temperature:

Calibration Temperature: 23 ° C \pm 1 ° C
Ambient Temperature: 20 ° C to 30 ° C
Operating Limit: 10 ° C to 50 ° C
Storage Temperature: -40 ° C to 85 ° C

Dimension: W 19 x H 3.5 x D 21 inches; W 480 x H 88 x D 530 mm

Weight: 21.5 lbs., 9.75 kg. Shipping 23 lbs., 10.43 kg

Terminals: Output: Front panel mounted, 5 way binding posts
which are: floating, Opto-isolated from the 488 bus, guarded, remote sensed (4 wire) and case ground. Rear panel mounted 6 pin Amphenol spec. connector (mate supplied) with the same functions as those listed for the front panel connections. (No additional charge).

1.6.0 General Information

Mounting: Rack mounting facilities; standard 19 ", 482.6mm and for bench use with convenient, and removable, tilt bale, included.

Certification: A Certificate of Compliance is issued with each new instrument to certify the calibration traceable to the National Institute of Standards and Technology (N.I.S.T.).

Warranty: Full ONE YEAR warranty on parts and labor and a full ONE YEAR warranty on specifications and performance.

SECTION II

2.0.0 **INSTALLATION**

2.1.0 Mounting

The 522 is designed for mounting in a standard 19" relay rack. When installing in the rack it is recommended that nylon washers be placed under the mounting screws to prevent scratching the paint.

2.2.0 Mating Connectors

All instruments are supplied with a mating AC power cord and output connector. These are:

<u>Nomenclature</u>	<u>EDC Part Number</u>	<u>Quantity</u>
1) AC Power Cord	CAB008	1 ea.
2) Output Connector	CON015	1 ea.
3) Connector Clamp	CON013	1 ea.

2.3.0 IEEE Standard 488 Cable

A one or two meter IEEE Std. 488 cable may be obtained from EDC. EDC Part Number CAB011 for one meter & CAB010 for two meters.

2.4.0 AC Power Input Considerations

See paragraph 3.7.0 for power line voltage changing instructions.

2.5.0 Thermal Considerations

The heat generating components are located at the rear 4 inches of the unit. Locate the unit in the rack so that the rear 4 inches are not obstructed by other instruments, so as to permit the free flow of air for this convection system.

SECTION III

3.0.0 OPERATION OF THE INSTRUMENT

3.1.0 Front Panel Controls

- 3.1.1 Power Switch: Push-on, Push-off line power with associated indicator.
- 3.1.2 "Remote-Local" Switch: This switch has two positions. In the "local" position the instrument's output is controlled by the front panel switches. In the "remote" position the instrument is programmed by the IEEE bus, and disables all other front panel controls. This switch, when in the "local" mode, will override the 488 bus.
- 3.1.3 Polarity Switch: This switch has 3 positions. "+" polarity denotes that output terminal B, or red terminal, is positive with respect to output terminal C, or black terminal, and vice versa for "-" polarity. The "0" position produces a "crowbar" or short circuit "0" at the output terminals.
- 3.1.4 Magnitude Switches: There are six. Each one controls one decade of magnitude, and each is selectable from 0 to 10.
- 3.1.5 Range Switch: This is a six position switch selecting the six ranges: 100 mA, 10 mA, 100 mV, 10 V, 100 V or option.

3.2.0 Front Panel Indicators

- 3.2.1 Decimal Point Indicators: The decimal point always appears in the appropriate position depending upon which range is selected.
- 3.2.2 Instrument Status Enunciator

"REM" - indicates the instrument is in the remote mode with front panel controls disabled. The output status, i.e., polarity, magnitude, and range are indicated by the LED displays and is updated as the program is changed.

"LOC" - indicates the local or manual mode. All front panel controls are operational and override any programmed bus commands.

"OVLD" - When illuminated, indicates an overload or possibly shorted condition in the voltage mode. Or, an open circuit condition in the current mode.

NOTE: When the 522 senses an overload condition the unit will display "OVERLOAD" in the digit display area. When this happens the 522 will reset itself to crowbar and output zero. To return to the current range you must first remove the cause of the overload. Then you must either send more data if you are in remote mode, or turn one of the switches if you are in the local mode.

3.2.3 Range/Function Enunciator:

"mV" indicates millivolt range/and mode
"V" indicates Volt range/and mode
"mA" indicates milliampere range/and mode

3.2.4 Decimal Indicator: A "floating" decimal point is illuminated by several LEDs and properly locates the decimal point for the range indicated.

3.2.5 Magnitude Display Digits: Six (6) alpha-numeric displays indicate the analog value of the output. When the unit is turned on the segments are tested and at the end of the segment test, the 488 Bus address is displayed. In "local" the display then indicates the front panel switch settings. In "remote" the address is displayed until a valid sequence is sent to the unit over the IEEE Bus.

3.3.0 Output Connections

3.3.1 Front Panel Connections: All terminals on the front panel are 5 way binding posts. Spacing is the standard 3/4" centers. Connections are located as follows:

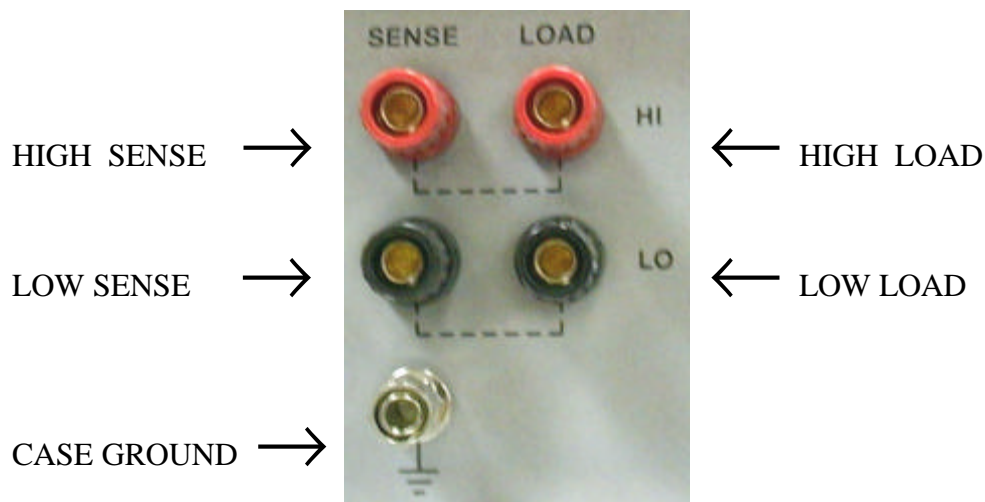

The "load" and "sense" refers to the 4 wire remote sense capability.

NOTE: THE "LOAD-SENSE" CIRCUIT MUST BE COMPLETE IN EITHER ONE OF TWO CONFIGURATIONS: (Please refer to Drawing #930727 in the rear of this manual for the two-wire and four-wire connections.

For the current mode or for driving high impedances in the voltage mode, only two wires have to be connected to load. See Figure 2 on drawing #930727.

However, if an appreciable current is to flow in the circuit, in the voltage mode, i.e. .1 mA, then the sense lines should be connected at the load. (See Figure 1 on Reference Drawing #930727)

This 4 wire system eliminates the IR drop and thus maintains the voltage accuracy, of the Model 522, at the load.

3.3.2 Rear Panel Connector:

- A Chassis ground
- B + (high) load
- C - (low) load
- D No Connection
- E - (low) sense
- F + (high) sense

The same 4 wire sense procedures apply at the connector as discussed in 3.3.1. (SEE FIGURE 3 ON REFERENCE DRAWING 930727).

3.3.3 Chassis Ground Terminals. These connections on the front panel and at the rear connector are connected to chassis ground.

3.4.0 Remote Programming Via The IEEE 488 Bus

3.4.1 Introduction. The EDC model 522 is compatible with the IEEE Std.488/1978. The applicable reference publication is: IEEE Standard Digital Interface for Programmable Instrumentation (IEEE Std. 488/1978).

Publisher: The Institute of Electrical and
Electronics Engineers, Inc.
345 East 47th Street
New York, NY 10017

The <GP-IB> makes it possible for a user to connect various instruments and components together into a functional system. However, this system will not work without the proper software.

The operating system software offers a set of functions and commands which the user can assemble into a written program. Once written, the user's application program, in conjunction with the operation system software, will allow the various instruments on the <GP-IB> to generate signals, take measurements, and allow the instrument controller to manage the resulting information.

All commands sent over the <GP-IB> must be expressed in the controller's own language such as BASIC, FORTRAN, etc.

There are three steps that **MUST** be taken when using the <GP-IB> to make the system operate. The user **MUST**:

- a. Understand what tasks must be performed.
- b. Use the controller's language.
- c. Know what kind of information the instruments are capable of exchanging.
- d. **READ THE CONTROLLER PROGRAMMING MANUAL THOROUGHLY!!!**

3.4.1.1 The interface capabilities of the 522 are SH1, AH1, T6, L4, SR1, RL0, PP2, DC0, DT0, E1, (see para. 3.4.4.1 for PP2 exception).

3.4.2 Setting The Instrument's Listen Address. The EDC 522 is both a "Listener and a limited Talker" instrument. Its address is set with a "dip switch" located on the rear panel.

NOTE: THE BUS ADDRESS IS DISPLAYED UPON GOING FROM LOCAL TO REMOTE, AND THE DISPLAYED ADDRESS IS THE DEVICE NUMBER THE MODEL 522 WILL RESPOND TO. HOWEVER IF THE ADDRESS SWITCH IS CHANGED WHILE IN THE REMOTE MODE, THE DISPLAY WILL NOT INDICATE THE NEW ADDRESS, ALTHOUGH THE INSTRUMENT WILL NOW RESPOND TO THE NEW ADDRESS.

3.4.2.1 Use switches 1 through 5. They are **BINARY** coded.

- SW1 = Bit 1
- SW2 = Bit 2
- SW3 = Bit 4
- SW4 = Bit 8
- SW5 = Bit 16
- ON = True
- OFF = False

Binary numbers 0 through 30 are acceptable. **DO NOT SET ALL 5 SWITCHES TO "ON"**.

3.4.3 Interface Messages. The EDC 522 will respond to the following interface messages:

"MLA". - My Listen Address. Upon receipt of this message, the instrument will enter its listener active state and be ready to accept a string of data bytes. **ATN** must be true.

"MTA". - My Talk Address. Upon receipt of this message, the instrument will enter its Talk state and transmit a message string as defined in Para.3.4.4.3.

"UNL". Unlisten. Upon receipt of this message, the instrument will enter its listener idle state and will not listen to any subsequent data byte strings.

ATN must be true.

"IFC". Interface Clear. Upon receipt of this command the instrument will enter its listener idle state.

"Power-On" Clear. On "Power-On", and remote mode, the instrument will be in the listener idle state and its analog output will be 0. The instrument will also go to its listener idle state when in the local mode.

3.4.3.1 There are several groups of commands which the 522 will act upon, when received over the bus:

- A. Normal messages to program the unit's output to a specified voltage.
- B. Messages requesting specific responses on the condition of the 522.
- C. Serial Poll in response to a SRQ.
- D. Parallel Poll to indicate device status.
- E. Interface Clear (IFC)

3.4.4 Data Byte String Format. In general, the 522 is programmed with an eight character data byte string. ATN must be false on these bytes.

CHARACTER	FUNCTION	ASCII CODES
1	Polarity	+ = Positive Polarity 0 = Crowbar "0" - = Negative Polarity
2	MSD	0 - 10 (For Decimal 10 Use "J")
3	2SD	0 - 10 (For Decimal 10 Use "J")
4	3SD	0 - 10 (For Decimal 10 Use "J")
5	4SD	0 - 10 (For Decimal 10 Use "J")
6	5SD	0 - 10 (For Decimal 10 Use "J")
7	6SD	0 - 10 (For Decimal 10 Use "J")
8 EOI	Range (See section 6.1.6 if RA-7 is installed)	0 = 100 mV 1 = 10 V 2 = 100 V 3 = 1000 V 4 = 10 mA 5 = 100 mA CR LF or LF if EOI has not been sent

The analog output will change to a new value after receiving the end of message.

NOTE: the 522 should see an eight, (8) character word for correct programming. It will act on the first 8 bytes. The 522 must receive an end of message terminator to act on the

message. It will recognize CR LF, LF, OR EOI with the last byte as a terminator.

3.4.4.2 Talk Enable Modes:

The controller may request specific status information from the EDC MODEL 522. The messages to be sent to the EDC MODEL 522 prior to sending an MTA are as follows:

Identification query	ID?(eoi)
Last Data Sent	B(eoi)
What's wrong	?(eoi)

3.4.4.3 Upon receipt of any of the above messages, and upon receipt of MTA, the EDC MODEL 522 will respond with the appropriate information:

ID?: Returns instrument model number and firmware version number:

"KROHN-HITE, 522, VER 2.10 "

B: Eight (8) byte message string. (Consist of first eight bytes received over the bus, regardless of message length in excess of eight.)

?: One or more of the following ASCII messages:

"DATA ERROR"

"NO 1000 VOLT MODULE INSTALLED"

"CURRENT OVERLOAD"

"OVERLOAD"

"NOTHING WRONG"

"NOT PROGRAMMED"

3.4.4.4 The "What's wrong request, ("?"), may be sent at any time, the EDC MODEL 522 will respond with, "NOTHING WRONG" or one of the messages of Para 3.4.4.3. It is also used when the controller responds to an SRQ and the 522 response signifies an error condition.

3.4.4.5 The Model 522 sets the SRQ when an error is detected. The "Whats wrong request, ("?"), when sent will clear the SRQ.

3.4.5.0 Programming:

The following sample programs are intended as guides to help you program this calibrator.

National's Lab Windows driver for the 522 is available on request.

NOTE: *the 522 should see an eight, (8) character word for correct programming. It will act on the first 8 bytes. The 522 must receive an end of message terminator to act on the message. It will recognize CR LF, LF or EOI with the last byte as a terminator.*

In the following example:

The LANGUAGE is in BASIC, unless noted.

The INTERFACE is IEEE-488 (GPIB)

The ADDRESS is (Binary) 5 with the dip switch set:

dip switch settings

1	2	3	4	5	6	7
on	off	on	off	off	off	off

SAMPLE PROGRAM: Hewlett-Packard Model 9825

The following sample program is intended as a guide to help you program this calibrator.

```
1 REM MANUAL INPUT PROGRAM FOR EDC. 522
5 PRINT "{clr home}"
6 ED$=""
10 PRINTED$:PRINT"":PRINT"ENTER POLARITY + OR -"
20 INPUT P$
25 PRINT "{clr home}"
30 PRINT " ENTER MAGNITUDE IN SIX CHARACTERS; IE, 123456"
31 PRINT " FOR DECIMAL 10 USE J":PRINT""
40 INPUT M$:IF LEN(M$)<>6 GOTO30
45 PRINT "{clr home}":PRINTED$:PRINT""
50 PRINT " ENTER RANGE":PRINT"0 FOR 100 MV":PRINT"1 FOR 10V"
51 PRINT"2 FOR 100V"
52 PRINT"3 FOR 1000V":PRINT"4 FOR 10MA":PRINT"5 FOR 100MA"
60 INPUT R$: IF LEN(R$)<>1 GOTO50
65 PRINT "{clr home}":PRINTED$:
70 A$=(P$+M$+R$)
72 REM A$ IS DATA MESSAGE SENT ON THE BUS TO 522
75 PRINT"":PRINT" INPUT TO 522 ON THE BUS IS A$, A$="A$
100 T$=CHR$(13)
110 OPEN5,5
120 WRT7XX,A$; CHR$(13):REM-OR WRT7XX,"T123456R";CHR$(13);
130 CLOSE5
135 PRINT"INPUT COMPLETE":PRINT"":PRINT""
140 PRINT"TO ENTER MORE DATA, PRESS SPACE BAR":PRINT""
150 GETX$:IFX$=""THEN150
160 GOTO5
```

RS-232 OPTION

3.5.0 Remote Programming Via The RS-232 Bus

3.5.1 Setting The Instrument's Baud rate. Its Baud rate is set with a "dip switch" located on the rear panel.

***NOTE:** the baud rate is displayed upon going from local to remote, and the displayed rate is the only rate the model 522 will respond to correctly. If the baud switch is changed while in the remote mode, the instrument must be returned to local and back to remote for the instrument to respond to the new baud rate.*

3.5.1.1 Use switches 1 through 4.

BUAD RATE	1	2	3	4
50	1	0	0	0
75	0	1	0	0
109.92	1	1	0	0
134.58	0	0	1	0
150	1	0	1	0
300	0	1	1	0
600	1	1	1	0
1200	0	0	0	1
1800	1	0	0	1
2400	0	1	0	1
3600	1	1	0	1
4800	0	0	1	1
7200	1	0	1	1
9600	0	1	1	1
19,200	1	1	1	1

3.5.2 Data Byte String Format. In general, the 522 is programmed with an eight character data byte string.

CHARACTER	FUNCTION	ASCII CODES
1	Polarity	+ = Positive Polarity 0 = Crowbar "0" - = Negative Polarity
2	MSD	0 - 10 (For Decimal 10 Use "J")
3	2SD	0 - 10 (For Decimal 10 Use "J")
4	3SD	0 - 10 (For Decimal 10 Use "J")
5	4SD	0 - 10 (For Decimal 10 Use "J")
6	5SD	0 - 10 (For Decimal 10 Use "J")
7	6SD	0 - 10 (For Decimal 10 Use "J")
8	Range (See section 6.1.6 if RA-7 is installed)	0 = 100 mV 1 = 10 V 2 = 100 V 3 = 1000 V 4 = 10 mA 5 = 100 mA

The analog output will change to a new value after receiving the message.

NOTE: The 522 should see an eight, (8) character word for correct Programming.

3.5.3.0 Programming via RS-232:

The following sample program is intended as a guide to help you program this calibrator.

NOTE: The 522 should see an eight, (8) character word for correct Programming.

The controller should be set for NO PARITY, 8 BITS, AND 1 STOP BIT.
The message should be sent across in Binary to avoid adding CR, LF.

In the following example:

The LANGUAGE is QUICKBASIC.

3.5.3.1 The following sample program is intended as a guide to help you program this calibrator.

```
REM MANUAL INPUT PROGRAM FOR EDC. 522
CLS
OPEN "COM1:1200,N,8,1,BIN" FOR RANDOM AS 2
1 PRINT "": PRINT "ENTER POLARITY + OR -"
INPUT P$
2 CLS
PRINT " ENTER MAGNITUDE IN SIX CHARACTERS; IE, 123456"
PRINT " FOR DECIMAL 10 USE J": PRINT ""
INPUT M$: IF LEN(M$) <> 6 THEN GOTO 2
3 CLS
PRINT " ENTER RANGE": PRINT "0 FOR 100 MV": PRINT "1 FOR 10V"
PRINT "2 FOR 100V"
PRINT "3 FOR 1000V": PRINT "4 FOR 10MA": PRINT "5 FOR 100MA"
INPUT R$: IF LEN(R$) <> 1 THEN GOTO 3
CLS
A$ = (P$ + M$ + R$)
REM A$ IS DATA MESSAGE SENT ON THE BUS TO 522
PRINT "": PRINT " INPUT TO 522 ON THE BUS IS A$, A$="; A$
PRINT "INPUT COMPLETE": PRINT "": PRINT ""
GOSUB 10
PRINT "TO ENTER MORE DATA, PRESS SPACE BAR": PRINT ""
4 X$ = INKEY$: IF X$ = "" THEN GOTO 4
GOTO 1
10 PRINT #2, (A$);
RETURN
```

3.6.0 Voltage Compliance Limit Control

This control pertains to the current mode only. It is a means to limit the potential (EMF) of the current output. The control is an internally mounted jumper that may be placed in any one of six positions. The control is located inside the instrument on the mother board. Figure 3-1 shows the jumper set to provide maximum compliance (factory default). Figure 3-2 shows the jumper set to position 4.

This control does not effect the operation of the Voltage mode.

Jumper Position	Nominal Usable Compliance Voltage	Nominal Open Circuit Voltage
1 (minimum)	1.2 V	1.2 V
2	4 V	14 V
3	14 V	24 V
4	23 V	33 V
5	65 V	75 V
6 (maximum)	100 V	150 V

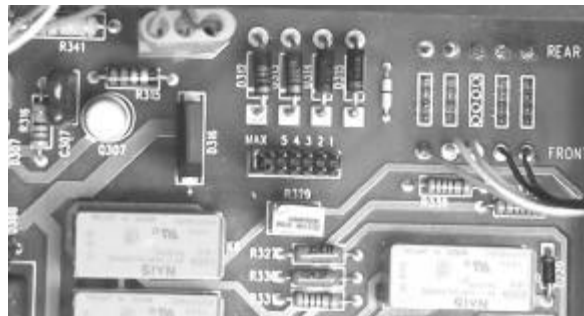

Figure 3-1 Maximum compliance

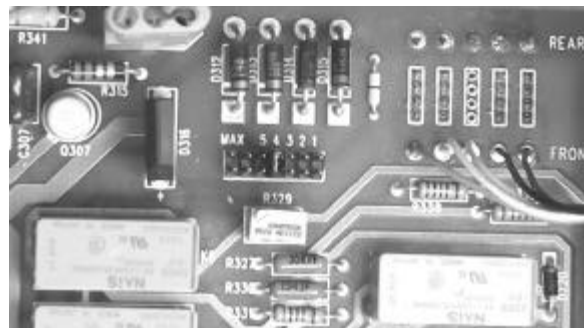

Figure 3-2 Jumper position 4

3.7.0 Operating Voltage Conversion

3.7.1. The 522 will operate on either 100, 120, 220 or 240 Vac line voltage. The following paragraphs explain how to change the voltage settings and the fuse.

3.7.2 The cover of the Power Entry Module shows four possible voltage settings (100V, 120V, 220V or 240V). Notice that a pin will be in one of these holes, indicating the present voltage setting for the 522. If this setting does not match the voltage available at your site, then it must be changed before powering on the 522. Figure 3-3 shows an example setting for 120 Vac operation.

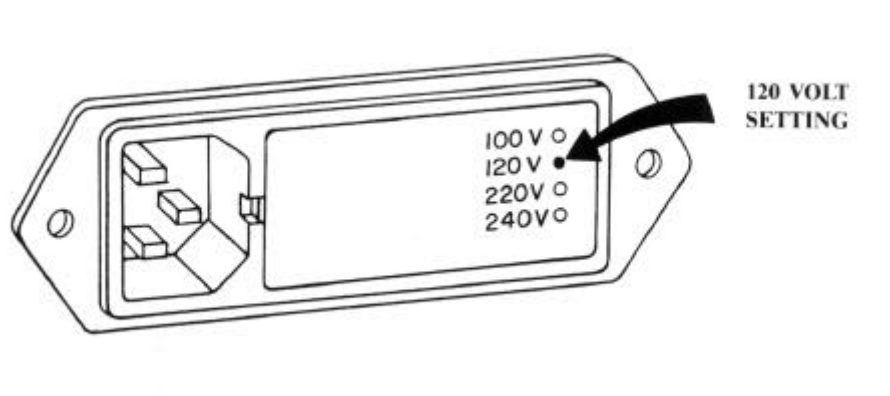

FIGURE 3-3 EXAMPLE 120 VOLT SETTING

3.7.3 Follow the steps below to change a fuse or convert the operating voltage of a 522.

1. Set the 522 power switch to OFF.
2. Unplug the power cord from the ac wall outlet and from the power cord receptacle on the power entry module. See Figure 3-4.
3. Using a small flat blade screwdriver or similar tool inserted into the slot at the left edge of the cover, carefully pry the cover off the fuse cavity.
4. To change the voltage setting, grasp the white plastic voltage select board pin and pull straight outward until the voltage select board unseats from the power entry module. Hold the board so that you can read the four voltage selection labels (100, 120, 220 and 240) imprinted on the board. Move the voltage indicator pin to the opposite side of the board from the desired voltage label. Be sure to seat the pin in the notch provided on the board's edge. Install the voltage select board so that it is fully seated in the voltage select cavity (the label side toward the fuse cavity).
5. To change the fuse (s), remove the fuse (s) from the fuse carrier on the back of the cover. For 100 or 120 Vac operation, the fuse rating is 3/4 Amp, Slo-Blo. For 220 or 240 Vac operation, the fuse rating is 0.5 Amp, Slo-Blo. Be sure to use the correct rating for your voltage selection. For installation, insert the fuse(s) of the proper rating into the fuse carrier.

6. To change the fuse arrangement to match that used in your country, remove the screw from the fuse carrier, remove the fuse carrier, turn the fuse carrier so that the desired fuse arrangement (single fuse or dual fuses) is facing outward, install the fuse carrier, and install the screw. For United States type power operation, use a single standard AGC or 3AG 0.25 inch x 1.25 inches fuse of the correct rating. For European type power operation, use two standard 5.2 mm x 20 mm fuses of the correct rating. For European use, it is important to note that if your local electrical code does not allow a dual fuse arrangement, then a dummy fuse must be installed in the lower fuse carrier. Otherwise, the 522 will not operate.
7. Place the cover on the power entry module and press inward until it snaps into place. Verify that the desired operating voltage is indicated with the voltage select board pin on the cover label.
8. Connect the power cord to the power entry module and wall outlet. The 522 is now ready to be operated on the selected ac line voltage.

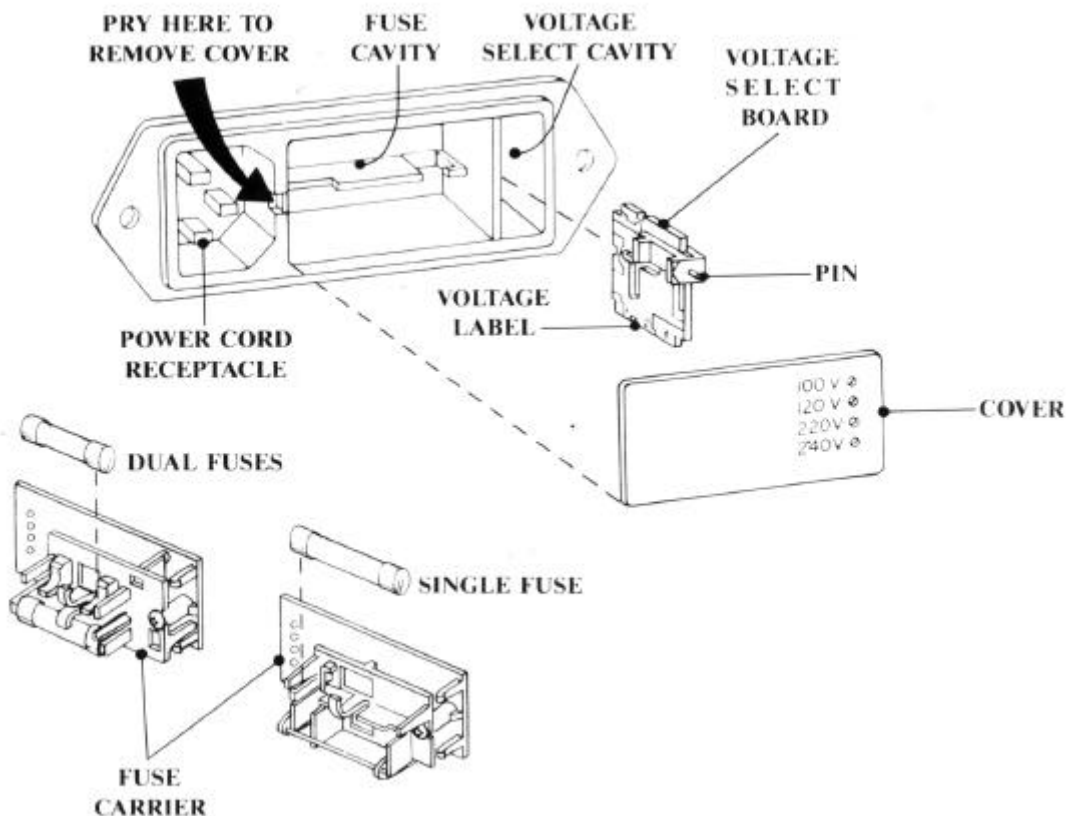
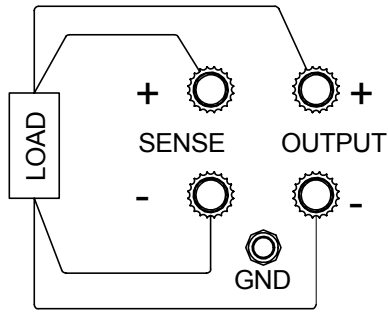
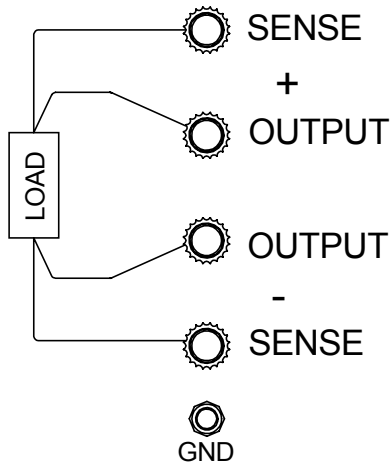

FIGURE 3-4. POWER ENTRY MODULE

SENSE CONNECTIONS

HIGH CURRENT LOAD



[Sense Links Removed]

FIG 1

LIGHT LOAD

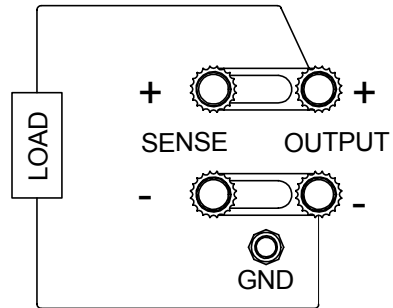
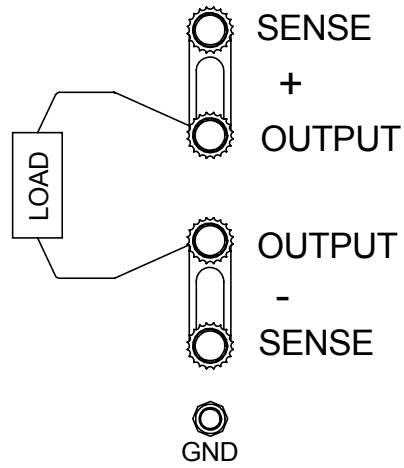

[Sense Links Installed]

FIG 2

OUTPUT CONNECTOR PIN FUNCTIONS

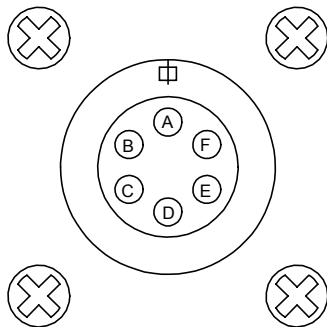

- PIN A Chassis Ground
- PIN B + Output
- PIN C - Output
- Pin D Not Used
- Pin E - Sense
- Pin F + Sense

FIG 3